



Operator's Manual

15° Coil Nailer

Model No. CN70-15
Item No. 65560

Drives Wire Collated Nails
1-3/4" to 2-3/4" / 45 to 70mm



Ask for
Genuine
INTERCHANGE®
HWCF Nails

NOTE: Please read and fully understand the instructions in this manual before operating the pneumatic power tool. Carefully read through this OPERATOR'S MANUAL to ensure efficient, safe operation. It is recommended that the MANUAL be kept readily available as an important reference when using this tool.

15° Coil Nailer

Drives Wire Collated Nails (1-3/4" to 2-3/4" / 45 to 70mm)

Model No. CN70-15

Item No. 65560

Index

Information	Page
Important Information	3
Tool Information	
Nailer Specifications	4
Applications	4
Nail Specifications	4
Parts Identification	5
Accessories	5
Safety Information	
Safety Instructions	6-9
Employer's Responsibilities	9
Operating the Nailer	
Air Supply, Connections & Operating Pressure	10-11
Lubrication	11
Operating Instructions	12
Nail Loading	13
Testing the Nailer	14
Methods of Operation	14-15
Troubleshooting	15
Maintenance and Inspection	16
Parts Drawing/Schematics, Parts List, Parts Kits	
Parts Drawing/Schematics	17
Parts List	18
Parts Kits	19
Warranty	Back Cover

15° Coil Nailer

Drives Wire Collated Nails (1-3/4" to 2-3/4" / 45 to 70mm)

Model No. CN70-15

Item No. 65560

Important Information

WARNING: The warnings, cautions and instructions discussed in this instruction manual can not cover all possible conditions and situations that may occur. It must be understood by the operator that common sense and caution are factors which can not be built into this product, but must be supplied by the operator.



When using the tool, basic safety precautions should always be followed to reduce the risk of personal injury and damage to equipment.

Read and understand tool labels and operating instructions, safety precautions and warnings in this manual before operating or maintaining this nailer.

Failure to follow warnings could result in **DEATH** or **SERIOUS INJURY**.

Most accidents that result from the operation and maintenance of nailers are caused by the failure to observe basic safety rules or precautions. An accident can often be avoided by recognizing a potentially hazardous situation before it occurs and by observing appropriate safety procedures.

Basic safety precautions are outlined in the "**SAFETY**" section of this Manual and in the sections which contain the operation and maintenance instructions.

Hazards that must be avoided to prevent bodily injury or tool damage are identified as **DANGERS** or **WARNINGS** on the nailer and in this Manual.

Never allow the nailer to be operated by children or individuals who have not reviewed this manual.

OPERATE THE NAILER ACCORDING TO THIS MANUAL.



WARNING!

- Always follow the tool manufacturer's safety and maintenance instructions.
- Always wear safety glasses with side shields when operating or servicing tools.
- Always disconnect the air supply from the tool and empty the magazine when servicing tools.

**SAVE THIS MANUAL
FOR FUTURE REFERENCE!**

15° Coil Nailer

Drives Wire Collated Nails (1-3/4" to 2-3/4" / 45 to 70mm)

Model No. CN70-15

Item No. 65560

Tool Information

Nailer Specifications: CN70-15 Coil Nailer

Tool Dimensions - Length x Height x Width	12-7/16" x 12-1/16" x 5" (315mm x 306mm x 128mm)
Weight	8.07 lbs. (3.67 kgs.) Aluminum Body 7.44 lbs. (3.38 kgs.) Magnesium Body
Magazine Capacity	225 to 300 Nails
Recommended Operating Pressure	70 to 120 psi / 5 to 8.5 kgs.

Applications

Assembly and Repair of Pallets, Boxes, Fencing and Crates. General Construction Applications Including: Floor and Wall Framing, Siding, Decking, Sheathing, Subflooring and Wood Shingles.

Nail Specifications

WARNING: Be sure to use only the genuine nails recommended for the CN70-15. The use of any other nails can result in tool malfunction, leading to serious injuries.

Only the nail sizes shown in the table below can be driven with this nailer.

FASTENERS:

Wire Welded Nail Length	1-3/4" to 2-3/4" / 45 to 70mm
Shank Diameter	0.092" to 0.113" / 2.3 to 2.9mm
Head Diameter	0.197" to 0.276" / 5.0 to 7.0mm
Shank Type	Smooth, Ring, Screw

DIMENSIONS OF FASTENERS:

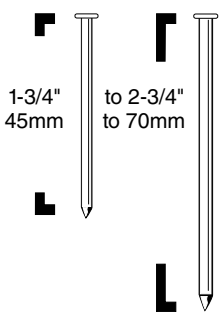
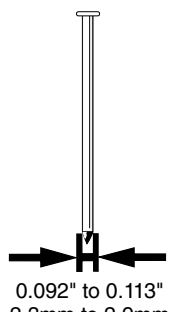
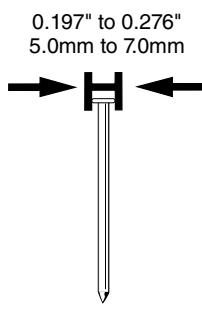
15° Coil Nails - Flat, Wire Weld Collated		
Nail Length	Shank Diameter	Head Diameter
 <p>1-3/4" 45mm</p> <p>to 2-3/4" to 70mm</p>	 <p>0.092" to 0.113" 2.3mm to 2.9mm</p>	 <p>0.197" to 0.276" 5.0mm to 7.0mm</p>

15° Coil Nailer

Drives Wire Collated Nails (1-3/4" to 2-3/4" / 45 to 70mm)

Model No. CN70-15

Item No. 65560

Parts Identification

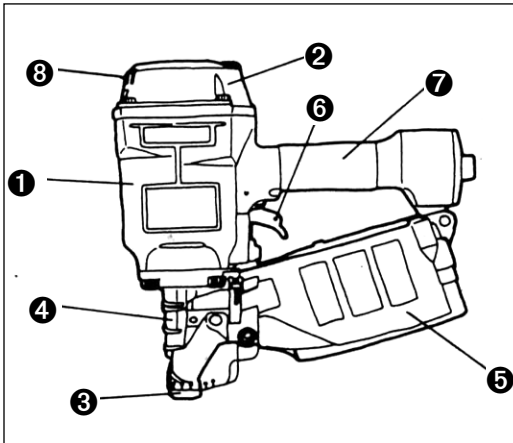

- ① Casting
- ② Cylinder Cap
- ③ Safety
- ④ Guide Body
- ⑤ Magazine
- ⑥ Trigger
- ⑦ Grip
- ⑧ Exhaust Cover

TOOL AIR FITTINGS: This tool uses a minimum 1/4" N.P.T. male plug. The inside diameter should be 0.28" (7mm) or larger. The fitting must be capable of discharging tool air pressure when disconnected from the air supply.

RECOMMENDED OPERATING PRESSURE:

70 to 120 psi / 5 to 8.5 kgs.

Select the operating air pressure within this range for best fastener performance.

Accessories

STANDARD ACCESSORIES



1	Eye Protection	1
---	----------------	---

Safety Information



Important Safety Instructions for Operating Nailers READ ALL INSTRUCTIONS



1. OPERATORS AND OTHERS IN WORK AREA MUST WEAR SAFETY GLASSES WITH SIDE SHIELDS.

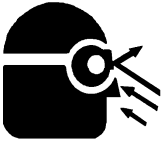

Danger to the eyes exists due to the possibility of flying fasteners and debris when operating the nailer. To guard against these hazards always wear safety glasses with side shields to protect both the front and sides. Make sure others in the work area wear safety glasses, too.

Eye protection equipment must conform to the requirements of American National Standards Institute, ANSI Z87.1.

The employer is responsible to enforce the use of eye protection equipment by the tool operator and other personnel in the work area.

2. EAR AND HEAD PROTECTION MAY BE NEEDED IN SOME ENVIRONMENTS.

Some work areas may include exposure to high noise levels which can lead to hearing damage. Always wear ear protection to protect your ears from loud noise. Wear head protection to protect your head from flying objects.



3. KEEP FACE, HANDS AND FEET AWAY FROM FIRING HEAD AT ALL TIMES.

Never place your face, hands or feet near the firing head.

4. KEEP FINGER AWAY FROM TRIGGER WHEN NOT DRIVING FASTENERS TO AVOID ACCIDENTAL FIRING.

Always carry the nailer by the handle only. Never carry the nailer with your finger on trigger since you could drive a fastener unintentionally and injure yourself or someone else.

5. NEVER POINT NAILER AT YOURSELF OR OTHERS IN WORK AREA.

Respect the nailer as a working implement. Always assume the nailer contains fasteners and never point the nailer at yourself or others, whether or not it contains fasteners. If fasteners are mistakenly driven, it can lead to severe injuries. Never engage in horseplay with the nailer.

6. DRESS PROPERLY.

Do not wear loose clothing or jewelry as they can be caught in moving parts. Rubber gloves and nonskid footwear are recommended when working outdoors. Wear protective hair covering to contain long hair.

7. KEEP VISITORS AWAY.

All visitors should be kept safely away from work area and should not handle the nailer.

8. KEEP OUT OF REACH OF CHILDREN.

9. DO NOT OVERREACH.

Keep proper footing and balance at all times.

15° Coil Nailer

Drives Wire Collated Nails (1-3/4" to 2-3/4" / 45 to 70mm)

Model No. CN70-15

Item No. 65560

10. STAY ALERT.

Watch what you are doing. Use common sense and do not operate the nailer when you are tired. The nailer should never be used if you are under the influence of alcohol, drugs or medication that makes you drowsy.

11. KEEP WORK AREA CLEAN.

Cluttered areas invite injuries. Clear all work areas of unnecessary tools, debris, etc.

12. DO NOT USE THE NAILER AS A HAMMER.

13. NEVER CARRY THE NAILER BY THE HOSE.

14. HANDLE THE NAILER CAREFULLY.

This nailer was designed for driving nails into wood and similar items. Operate the nailer safely and correctly and do not use for purposes other than those specified in this manual.

Because of high air pressure in the nailer, cracks in the surface are dangerous. To avoid tool damage, do not drop the nailer or strike the nailer against hard surfaces, and do not scratch or engrave on the nailer. Handle the nailer carefully.

15. BEFORE USING THE NAILER, CHECK TO MAKE SURE PARTS ARE NOT BROKEN OR MISSING AND THAT ALL SCREWS ARE TIGHT. DO NOT OPERATE A TOOL THAT IS OPERATING ABNORMALLY.

If the nailer appears to be operating unusually, making strange noises, has parts missing or appears to be defective, stop using it immediately and arrange for repairs by an authorized service center.

16. BEFORE STARTING WORK, CHECK TO SEE IF YOUR TOOL HAS A FASTENING OPERATION SWITCHING DEVICE.

(Not available on all tool models.)

If this nailer includes a fastening operation switching device, check the setting of the operation switching device before starting work. If the switching device is not set properly, the nailer will not operate correctly.

17. CHECK SAFETY/PUSH LEVER BEFORE USE.

Make sure the safety/push lever operates properly. Never use the nailer unless the safety/push lever is operating properly, otherwise the nailer could drive a fastener unexpectedly. Do not tamper with or remove the safety/push lever, otherwise the safety/push lever becomes inoperable.

18. CHOICE OF TRIGGER METHOD IS IMPORTANT.

Read and understand section titled "Methods of Operation."

(Choice of trigger method is not available on all tool models.)

19. DO NOT USE OXYGEN, COMBUSTIBLE OR OTHER BOTTLED GASES. EXPLOSION MAY OCCUR.

Never use oxygen, combustible gases or any other bottled gases as a power source for the nailer. Use of these gases is dangerous, as the nailer will explode.

Use only clean, dry, regulated compressed air as a power source.

20. DO NOT EXCEED 100psi.

Do not exceed maximum recommended air pressure 100psi. Never connect the nailer to pressure which potentially exceeds 150psi as the nailer can burst.

21. NEVER USE IN PRESENCE OF FLAMMABLE LIQUIDS OR COMBUSTIBLES.

The nailer produces sparks during operation. Never use the nailer on sites containing lacquer, paint, benzine, thinner, gasoline, gases, adhesive agents or other materials which are combustible or explosive.

22. KEEP ALL SCREWS AND COVERS MOUNTED TIGHTLY IN PLACE.

Keep all screws and covers tightly mounted. Check their condition periodically. Never use the nailer if parts are missing or damaged.

23. DO NOT USE THE WRONG FITTING ON NAILER.

The nailer and air hose must have a hose coupler so that all pressure is removed from the nailer when the coupler is disconnected. The connector on the nailer must not hold pressure when the air supply is disconnected. If the wrong fitting is used, the nailer can remain charged with air after disconnecting and thus will be able to drive a nail even after the air line is disconnected, possibly causing injury.

24. DO NOT LOAD FASTENERS WITH TRIGGER PULLED OR SAFETY/PUSH LEVER DEPRESSED.

When loading fasteners into the nailer or when connecting the air hose:

- Do not pull the trigger
- Do not depress the safety/push lever
- Keep the nailer pointed downward

25. CHECK FOR LIVE WIRES.

Avoid the risk of severe electrical shock by checking for live electrical wires that may be hidden by walls, floors or ceilings. Turn off the breaker switch to ensure there are no live wires.

26. HOSES.

Air hoses should be professional grade and have a minimum of 150 psi working pressure. Make sure that the hose is securely fastened. If there is any damage to the hose, replace it before using the nailer.

27. PLACE NAILER PROPERLY ON WORK PIECE.

Do not drive fasteners on top of other fasteners or with the nailer at too steep of an angle. The fasteners can ricochet and hurt someone.

28. BE CAREFUL OF DOUBLE FIRING DUE TO RECOIL.

If the safety/push lever is unintentionally allowed to re-contact the work piece following recoil, an unwanted fastener will be driven.

In order to avoid this undesirable double fire:

- Intermittent operation (trigger or single firing)
(*not available on all models*)
 - 1) Set the switching device to SINGLE ACTUATION MECHANISM.
 - 2) Pull the trigger rapidly and firmly.
- Continuous operation (safety/push lever firing)
 - 1) Do not press the nailer against the wood with excessive force.
 - 2) Separate the nailer from the wood as it recoils after fastening.

29. DO NOT DRIVE FASTENERS CLOSE TO THE EDGE OR CORNER OF THE WORK ESPECIALLY WHEN USING THIN MATERIAL.

The work piece is likely to split and the fastener could fly free and hit someone.

30. NEVER DRIVE FASTENERS FROM BOTH SIDES OF A WALL AT THE SAME TIME.

The fasteners could be driven into and through the wall and hit a person on the opposite side.

31. DO NOT DISCONNECT AIR HOSE FROM NAILER WHILE FINGER IS ON THE TRIGGER.

The nailer can fire when it is re-connected to an air supply.

15° Coil Nailer

Drives Wire Collated Nails (1-3/4" to 2-3/4" / 45 to 70mm)

Model No. CN70-15

Item No. 65560

32. DISCONNECT THE AIR SUPPLY AND EMPTY THE MAGAZINE WHEN THE NAILER IS NOT IN USE. NEVER LEAVE A NAILER UNATTENDED WITH THE HOSE ATTACHED.

Always disconnect the air supply from the nailer and empty the magazine when operation has been completed or suspended, when unattended, moving to a different work area, adjusting, disassembling, or repairing the nailer, and when clearing a jammed fastener.

33. DISCONNECT AIR HOSE FROM NAILER WHEN:

- Doing maintenance and inspection
- Loading fasteners
- Clearing a jam
- It is not in use
- Leaving work area
- Moving it to another location
- Handing it to another person

34. MAINTAIN NAILER WITH CARE.

Keep the nailer clean and lubricated for better and safer performance.

35. USE ONLY AUTHORIZED OR RECOMMENDED PARTS, ACCESSORIES OR FASTENERS.

Unauthorized parts, accessories or fasteners may void your warranty and can lead to tool malfunction and resulting injuries. Only authorized service personnel should repair the nailer.

36. NEVER MODIFY OR ALTER A NAILER.

Doing so may cause it to malfunction and personal injuries may result. The warranty is no longer valid when a tool is modified or altered.

37. BE CAREFUL WHEN CLEANING TOOL WITH A BLOW GUN.

Do not touch the trigger, point the air outlet at a person, touch the safety/push lever, or set it to pushed up status.

38. STORE NAILER PROPERLY.

When not in use, the nailer should be stored in a dry place. Keep out of reach of children and lock the storage area.

Employer's Responsibilities

- 1.** Ensure that this manual is available to operators and personnel performing maintenance.
- 2.** Ensure that nailers are used only when operators and others in work area are wearing **EYE PROTECTION**.
- 3.** Keep nailer in safe working order.
- 4.** Maintain nailer properly.
- 5.** Ensure that the nailers that require repair are not used before the repair is completed.

15° Coil Nailer

Drives Wire Collated Nails (1-3/4" to 2-3/4" / 45 to 70mm)

Model No. CN70-15

Item No. 65560

Operating the Nailer

NOTE: The information contained in this Manual is designed to assist you in the safe operation of the nailer. Some illustrations in this Manual may show details or attachments that are different from those on your nailer.

Air Supply, Connections and Operating Pressure

Read section titled **SAFETY**. Make sure of the following before operation:

Air Supply

Power Source (Compressor)

- Use only clean, dry, regulated compressed air as a power source for this nailer.
- NEVER use oxygen or other bottled gases, as an explosion may occur.
- Air compressors used to supply compressed air to this nailer must comply with the requirements of the latest version of ANSI Standard B 19.3 Safety Standard for Compressors for Process Industries.
- Moisture or oil in the air compressor may accelerate wear and corrosion in the nailer.
- Drain daily.

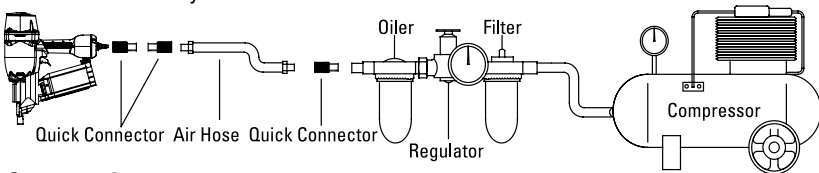

Connections

1. Fittings

Install a female coupler to the hose. The female coupler will connect to the quick release that fits the tool.

2. Filter-Regulator-Lubricator

- NEVER connect nailer to pressure which potentially exceeds 150psi.
- Filter-regulator-lubricator units supply an optimum condition for the nailer and extend the nailer life. These units should always be used.

Filter

- The filter removes moisture and dirt mixed in compressed air.
- Keep the filter clean by maintaining tool regularly.
- Drain daily.

Regulator

- The regulator controls the operating pressure for safe operation of the nailer.
- Inspect the regulator before operation to be sure it operates properly.

Lubricator

- The lubricator supplies an oil mist to the nailer.
- Inspect the lubricator before operation to be sure the supply of lubricant is adequate.
- If an inline lubricator is not used, a few drops of oil will need to be added to the air inlet before each use.

3. Air Hose

Air hose must have a minimum working pressure rating of 150psi or 150% of the maximum pressure produced in the system, whichever is higher.

Operating Pressure

- Recommended operating pressure range is 70 to 120 psi / 5 to 8.5 kgs.
- Maximum permissible operating pressure is 150 psi.
- Select the operating pressure within this range for the best fastener performance. The nail length and thickness and the hardness of the wood are factors in determining what the pressure should be set at.
- Do not exceed this recommended operating pressure.

Lubrication

It is important that the tool be properly lubricated. Without proper lubrication, the tool will not work properly and parts will wear prematurely.

- Use INTERCHANGE pneumatic tool lubricant. Do not use detergent oil or additives. These lubricants will harm the O-rings and other rubber parts. This will cause the tool to malfunction.
- Filter-regulator-lubricator units should always be used. Keep the lubricator filled with INTERCHANGE pneumatic tool lubricant.
- If a lubricator is not available, supply 3 to 5 drops of INTERCHANGE pneumatic tool lubricant into the air plug on the tool twice a day.

NOTE: Dirt and water in the air supply are major causes of wear in the tool. An air filter will help to get the best performance and minimum wear from the tool.

Frequent, but not excessive, lubrication is required for the best performance. Oil added through the air line connection will lubricate the internal parts.



WARNING

NEVER connect nailer to pressure which potentially exceeds 150psi.

DO NOT USE THE WRONG FITTING ON NAILER.

The nailer and air hose must have a hose coupler so that all pressure is removed from the nailer when the coupler is disconnected. The connector on the tool must not hold pressure when the air supply is disconnected. If the wrong fitting is used, the tool can remain charged with air after disconnecting and thus will be able to drive a nail even after the air line is disconnected, possibly causing injury.



DANGER

NEVER use oxygen or other bottled gases, as an explosion may occur.

15° Coil Nailer

Drives Wire Collated Nails (1-3/4" to 2-3/4" / 45 to 70mm)

Model No. CN70-15

Item No. 65560

Operating The Nailer

DANGER: Operators and others in work area must wear safety glasses with side shields that conform to ANSI Z87.1 specifications.

Read and understand METHODS OF OPERATION below.

Operating Instructions

Read section titled "SAFETY INSTRUCTIONS."

BEFORE OPERATION

1. Wear safety glasses or goggles with side shields.
2. Do not connect the air supply.
3. Inspect screws and tighten if necessary.
4. Check operation of the contact arm and trigger to make sure they are moving smoothly.
5. Connect the air supply.
6. Check the air-leakage. **(The tool must not have any air-leakage.)**
7. Hold the tool with finger off the trigger, then push the contact arm against the work piece. **(The tool must not operate.)**
8. Hold the tool with contact arm away from work piece and pull the trigger. **(The tool must not operate.)**
9. Disconnect the air supply.

OPERATION

Danger to the eyes exists due to the possibility of flying fasteners and debris when operating the nailer. To guard against these hazards always wear safety glasses with side shields to protect both the front and sides. Make sure others in the work area wear safety glasses, too.

Eye protection equipment must conform to the requirements of American National Standards Institute, ANSI Z87.1.

The employer and/or user must ensure that proper eye protection is worn. Eye protection equipment must conform to the requirements of the American National Standards Institute, ANSI Z87.1 and provide both frontal and side protection.

The employer is responsible to enforce the use of eye protection equipment by the tool operator and all other personnel in the work area.

NOTE: Spectacles and face shields without the side shields do not provide adequate protection.

Keep hands and body away from the discharge outlet when driving the fasteners to prevent striking the hands or body by mistake.

15° Coil Nailer

Drives Wire Collated Nails (1-3/4" to 2-3/4" / 45 to 70mm)

Model No. CN70-15

Item No. 65560

Nail Loading

1. OPEN THE MAGAZINE

Hold door and door latch and pull up door latch. Swing door open. Swing magazine cover open.

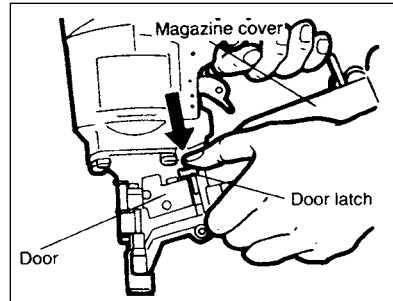

2. CHECK ADJUSTMENT

The nail support can be moved up and down to four settings. To change setting pull up on the post and twist to the correct step. The nail support should be adjusted correctly to the position indicated in inches and millimeters inside magazine.

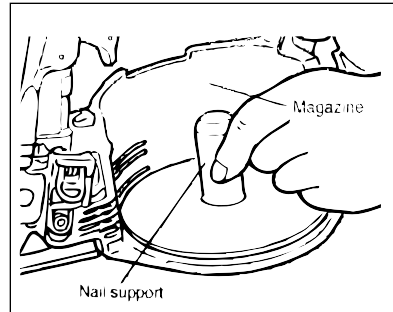

3. NAIL LOADING

Place a coil of nails over the post in the magazine. Uncoil enough nails to reach the feed pawl and place the second nail between the teeth on the feed pawl. The nail heads fit in slot on nose.

4. SWING COVER CLOSED

5. CLOSE THE DOOR

Check that the latch engages. (If it does not engage, check that the nail heads are in the slot on the nose).

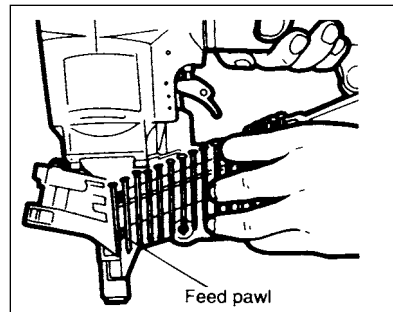

15° Coil Nailer

Drives Wire Collated Nails (1-3/4" to 2-3/4" / 45 to 70mm)

Model No. CN70-15

Item No. 65560

Testing The Nailer

Before using the nailer, test it by using the check list below.

If abnormal tests occur, stop using the nailer and contact an authorized service center immediately.

Conduct the test in the following order.

1. Adjust the air pressure to 70psi and connect the air hose.
2. Without touching the trigger, depress the contact arm against the work piece. Pull the trigger. (The tool must fire the fastener.)
3. With the tool off the work piece, pull the trigger. Depress the contact arm against the work piece. (The tool must fire the fastener.)
4. Adjust the air pressure to the lowest setting possible according to the diameters and length of fastener and the hardness of work piece.

Methods of Operation

Explanation of the nailing operation

■ Bump Fire (Multi-Fire)

- Pull the trigger with the nailer off the workpiece.
- Depress the push lever against the workpiece to drive a nail.
- Move the nailer along the workpiece with a bouncing motion.
- Each depression of the push lever will drive a nail.
- As soon as the desired number of nails have been driven, remove finger from the trigger.

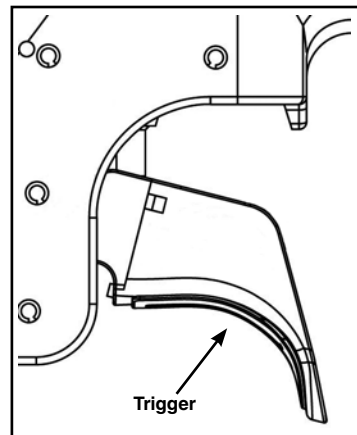

WARNING!

- Always follow the tool manufacturer's safety and maintenance instructions.
- Always wear safety glasses with side shields when operating or servicing tools.
- Always disconnect the air supply from the tool and empty the magazine when servicing tools.

15° Coil Nailer

Drives Wire Collated Nails (1-3/4" to 2-3/4" / 45 to 70mm)

Model No. CN70-15

Item No. 65560

Driving Depth Adjustment Dial

(on some models)

WARNING: Always disconnect air supply before changing the adjustment dial.

- With air pressure set, drive nails into a piece of scrap material to determine if an adjustment is necessary.
- If adjustment is required, disconnect air supply.
- Refer to the mark on the contact arm for direction to turn the adjustment dial.
- Reconnect air supply.

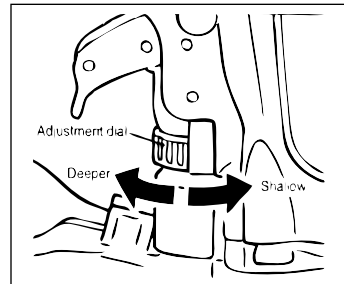

Directional Exhaust Cover

(on some models)

WARNING: Always disconnect air supply before rotating the exhaust cover.

■ Rotate Cover by Unscrewing

- Loosen screw as shown. Adjust to desired exhaust direction and tighten screw.

■ Rotate Cover by Hand

- Direction of the exhaust air can be changed by rotating exhaust cover by hand.

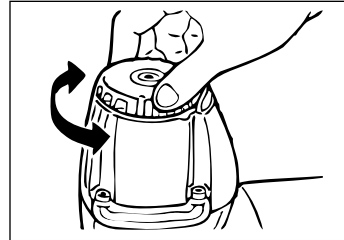
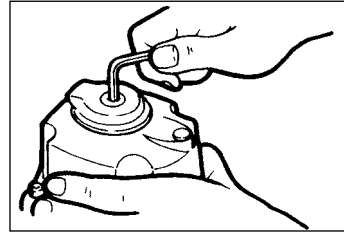

Troubleshooting

Problem	Cause	Solution
Trigger valve leaks air	O-ring is cut or cracked	Replace o-ring
Nose leaks air	O-ring or gasket is cut or cracked Bumper is cracked or worn	Replace o-ring or gasket Replace bumper
Failure to cycle	Air supply restriction Tool is dry, lack of lubrication Cap malfunction	Check air supply equipment Apply air tool lubricant Replace cap
Lack of power	Air pressure is too low	Check air supply equipment
Slow to cycle	Cap malfunction O-ring or seal is cut or cracked Tool is dry, lack of lubrication	Replace cap Replace o-ring or seal Apply air tool lubricant
Nails jam in tool	Bent nails Broken or chipped driver Wrong size nail	Replace with new nails Replace piston/driver assembly/bumper Replace with correct type of nail

Maintenance and Inspection

Read the section titled **SAFETY**.

SERVICE AND REPAIRS All quality tools will eventually require servicing or replacement of parts due to wear from normal use. It is recommended that these operations should be performed by a professional technician.

NOTE: The information contained in this Manual is designed to assist you in the safe maintenance of the nailer. Some illustrations in this Manual may show details or attachments that are different from those on your nailer.

WARNING: Disconnect air hose and remove nails from nailer when:

- Doing maintenance and inspection
- Clearing a jam

Inspecting the magazine

1. DISCONNECT AIR HOSE.
2. Clean the magazine. Remove dust which may have accumulated in the magazine.
3. Lubricate the nail rail with nailer lubricant.

Clearing a jam

Remove a jammed nail in the following order:

1. DISCONNECT AIR HOSE.
2. Remove all nails.
3. Remove the jammed nail with a slotted head screwdriver.
4. In case of frequent jams, contact an authorized service center.

A qualified person should perform repairs and maintenance.

Periodic maintenance to be performed:

- Check that the piston bumper is operating normally. A damaged piston bumper may cause damages to other component parts.
- Check o-rings for wear or damage. Damaged o-rings may affect overall performance.
- Make sure all screws are secure. Loose screws may affect overall performance.
- When repairing a tool, make sure the internal parts are clean and lubricated.

Storing

- When not in use for an extended period, apply a thin coat of the lubricant to the steel parts to avoid rust.

Cold Weather Care

- Do not store the tool in a cold weather environment. Keep the tool in a warm area until beginning the work.
 - If the tool is already cold, bring it in a warm area and allow the tool to warm up before use.
1. Reduce the air pressure to 60 to 80 psi (4.2 bar 4.2 kgf/cm²).
 2. Remove all fasteners from the tool.
 3. Connect the air hose and free-fire (blank-fire) the tool.

The lowered air pressure will be enough to free-fire the tool. Slow speed operation tends to warm up the moving part.

15° Coil Nailer

Drives Wire Collated Nails (1-3/4" to 2-3/4" / 45 to 70mm)

Model No. CN70-15

Item No. 65560

Parts Drawing/Schematics, Parts List & Parts Kits

PARTS DRAWING/SCHEMATICS FOR CN70-15

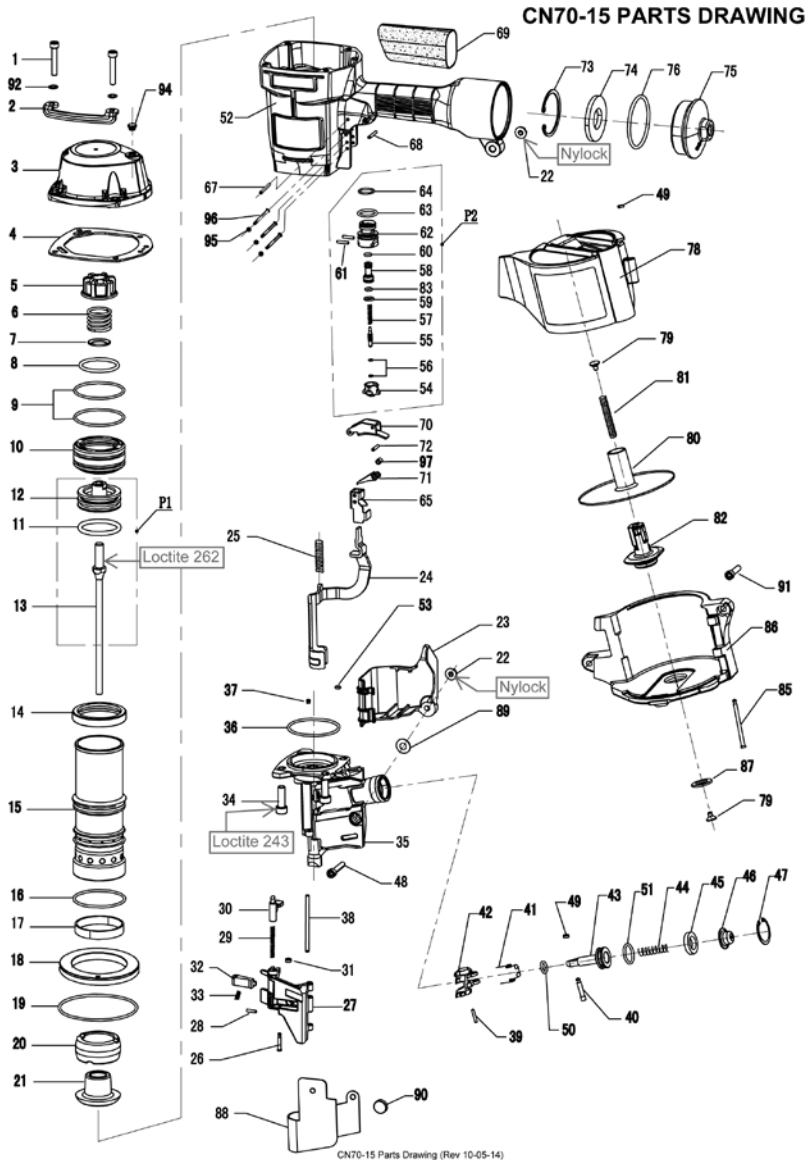

15° Coil Nailer

Drives Wire Collated Nails (1-3/4" to 2-3/4" / 45 to 70mm)

Model No. CN70-15

Item No. 65560

PARTS LIST FOR CN70-15

NO.	ORDER NO.	DESCRIPTION	NO.	ORDER NO.	DESCRIPTION
1	610570	BOLT M6X32	50	510320	O-RING 10X2.65
2	320470	SIDE PROTECTOR	51	510430	O-RING 20X2.65
3	110130	CYLINDER CAP	52	110110	BODY
4	520120	GASKET	53	510090	O-RING 4X1.5
5	410170	PISTON STOP	54	420080	TRIGGER VALVE CAP
6	620260	COMPRESSION SPRING	55	320110	TRIGGER STEM
7	320610	RING	56	510030	O-RING 2.5X1.4
8	510570	O-RING 41.2X3.55	57	620050	TRIGGER VALVE SPRING
9	510990	O-RING 55X3.1	58	330010	TRIGGER VALVE BUSHING
10	421410	HEAD VALVE PISTON	59	510240	O-RING 8.6X1.9
11	510970	O-RING 44X4.5	60	510180	O-RING 5.8X1.9
12	310140	PISTON	61	640250	STRAIGHT PIN B3X15
13	322080	DRIVER BLADE (Loctite 262)	62	420090	TRIGGER VALVE CAGE
14	420350	CYLINDER SEALING RING	63	510410	O-RING 18.3X2.65
15	310130	CYLINDER	64	510380	O-RING 16X1.8
16	510730	O-RING 56X2.65	65	320620	SAFETY LEVER BRACKET
17	520110	CYLINDER SEAL	66	#####	Replaced by #95 #96
18	420340	CYLINDER RING	67	640190	ROLL PIN 3X32
19	511660	O-RING 84X3.05	68	640160	ROLL PIN 3X25
20	410130	BUMPER A	69	410140	HANDLE GRIP
21	410120	BUMPER B	70	320570	TRIGGER
22	610330	NUT M6 (Nylock)	71	320560	CONTACT PLATE
23	420390	GUARD COVER	72	640340	ROLL PIN 3X16
24	320600	SAFETY	73	630020	SNAP RING
25	620250	SAFETY SPRING	74	420110	FILTER
26	322210	STEP PIN	75	110030	END CAP
27	210170	DOOR	76	510760	O-RING 58X3.55
28	640080	ROLL PIN 3X12	78	420410	MAGAZINE COVER
29	620240	LATCH SPRING	79	420240	SPRING HOLDER
30	210160	LATCH	80	320690	NAIL SUPPORT PLATE
31	420160	PIN CAP (B)	81	620290	MAGAZINE SPRING
32	210150	CHECK PAWL	82	420440	MAGAZINE POST
33	620230	CHECK PAWL SPRING	83	510210	O-RING 6.3X1.8
34	610300	BOLT M8X25 (Loctite 243)	84	#####	NOT APPLICABLE
35	210140	NOSE	85	320260	MAGAZINE PIN
36	510670	O-RING 50X1.8	86	420430	MAGAZINE
37	420150	PIN PLUG	87	410710	PLASTIC WASHER
38	320190	DOOR PIN	88	420420	DUST COVER
39	640340	ROLL PIN 3X16	89	320670	DUST COVER WAHSER
40	320210	FEED PAWL PIN	90	410060	RUBBER BUTTON
41	620280	FEED SPRING	91	610240	BOLT M6X35
42	210180	FEED PAWL	92	630070	SPRING WASHER
43	320640	FEED PISTON	93	#####	NOT APPLICABLE
44	620270	FEED PISTON SPRING	94	410650	RUBBER PIN CAP
45	410180	FEED PISTON BUMPER	95	410880	STRAIGHT PIN CAP
46	320630	FEED PISTON CAP	96	323150	STRAIGHT PIN
47	630050	SNAP RING	97	324520	TRIGGER SLEEVE
48	610250	BOLT M6X40	P1	D322081	DRIVER UNIT
49	420170	PIN CAP (A)	P2	T420091	TRIGGER VALVE

PARTS KITS FOR CN70-15

ORDER NO.	DESC. CODE	KIT #	ITEM
98300	CN70K1	Kit #1	O-Ring/Gasket Kit for CN70-15* (also fits CN80-15 & CN90-15)
98310	CN70K2	Kit #2	Piston/Driver Assembly for CN70-15
98320	CN70K3	Kit #3	Head Cap Assembly for CN70-15
98330	CN70K4	Kit #4	Trigger Valve Assembly with Trigger for CN70-15
98340	CN70K5	Kit #5	Magazine Assembly for CN70-15
98350	CN70K6	Kit #6	Guide Body Assembly for CN70-15
98351	CN70K7	Kit #7	Safety Kit for CN70-15
98352	CN70K8	Kit #8	Feeder Kit for CN70-15
98353	CN70K9	Kit #9	Bumper Kit for CN70-15

*Additional part in Kit #1: Order No. 510730 O-Ring 56X2.65

NOTICE: The parts listed in this manual are for service assembly and for reference. Changes to the tool and drawing may be made without notification.

Most parts or parts kits are available. Contact your local dealer for more information.

WARNING: When the tool needs repairing or servicing, it is strongly recommended that you contact your local dealer. Do not disassemble the tool yourself, which might waive your right for product guarantee.



WARNING!

- Always follow the tool manufacturer's safety and maintenance instructions.
- Always wear safety glasses with side shields when operating or servicing tools.
- Always disconnect the air supply from the tool and empty the magazine when servicing tools.

Limited Five (5) Year Warranty for Pneumatic Nailers

Our products are designed and constructed using the highest standards of both material and workmanship. We warrant to the original retail purchaser that their nailers will be free from defects in material or workmanship for the warranty period of five years.

During the warranty period (which begins on the purchase date), we will repair or replace, at our option and expense, any product or part that is defective in materials or workmanship after examination by an Authorized Warranty Service Center, subject to the exceptions, exclusions and limitations described below. Any replacement product or part will carry a warranty for the balance of the warranty period applicable to the replaced product or part. A DATED SALES RECEIPT OR PROOF OF PURCHASE FROM THE ORIGINAL RETAIL PURCHASER IS REQUIRED TO MAKE A WARRANTY CLAIM. To make a warranty claim, you must return the product, with proper receipt/proof of purchase and return transportation charges prepaid, to us (your dealer) or an Authorized Warranty Service Center. We will perform our obligations under this warranty within a reasonable time after approval of the warranty claim.

WARRANTY EXCLUSIONS

The following warranty exclusions apply:

1. Normal wear parts are not covered under this warranty. Normal wear parts include, for example, rubber o-rings, seals and driver blades.
2. This warranty does not cover parts damaged due to normal wear, misapplication, misuse, accidents, operation at other than recommended speeds, improper storage, or damage resulting during shipping.
3. Products used in production/industrial applications are excluded from this warranty.
4. Labor charges, maintenance, or loss, damage and repairs resulting from improper operation are not covered by this warranty.

GENERAL WARRANTY CONDITIONS

This warranty will be honored, only if:

1. Clean, dry, regulated compressed air has been used at air pressure not exceeding the maximum indicated on the tool casting;
2. No evidence of abuse, abnormal conditions, accident, neglect, misuse or improper modifications or storage of the product exists; and
3. No deviations from following recommended operating instructions, specifications, and maintenance schedules exist. (Read Operator Manual for use, specifications, and maintenance instructions).

This warranty is the only warranty for the product and we disclaim all other warranties. Any implied warranties will be limited in duration to the applicable warranty period specified above. Some states do not allow limitations on how long an implied warranty lasts, so the above limitation may not apply to you. Your remedies are solely and exclusively as stated above. We shall in no event be liable for incidental, consequential, indirect or special damages. Some states do not allow the exclusion or limitation of incidental or consequential damages, so the above limitation or exclusion may not apply to you. In no event, whether as a result of a breach of contract, warranty, tort (including negligence) or otherwise, shall our liability exceed the price of the product that has given rise to the claim or liability. Any liability connected with the use of this product shall terminate upon the expiration of the warranty period specified above. No employee or representative of any distributor or dealer is authorized to make any change or modification to this warranty.

This warranty gives you specific legal rights, and you may also have other rights, which vary from state to state.